

**Features:**

- Monoblock foldable main body
- Hinged, removable and lockable glass front door, t:4mm
- Removable and lockable side panels
- Optional fan-unit into the roof or 19inch rack mount type fan unit
- Vertical mounting rails are adjustable 4 step throughout the entire depth of the cabinet.
- Load carrying capacity 45kg



**Technical Data:**

Dimensions WxD in mm	W:600mm D:450/600mm
Height in U	7U – 9U – 12U – 16U
Color	RAL 7035 L.gray color or RAL 9005 Black color
Grounding continuity Standards	EN61587-1/ EN61010-1 TS EN 61587-1

**Mechanical Characteristics:**

Material	Sheet Steel, DIN EN 10130-99 / DC-01 6112 / DC-7122
Load Carrying Capacity	45kg
IP rating	IP20
Climatic Tests	C2
Industrial Atmosphere	A2
Static Mechanical Load Class	SL5 -LT5 -ST5 -NL5
Dynamic Mechanical Load Test	DL4V
Shock test	DL4S
Impact test	IK07

**Drawings for 450mm depth cabinets:**

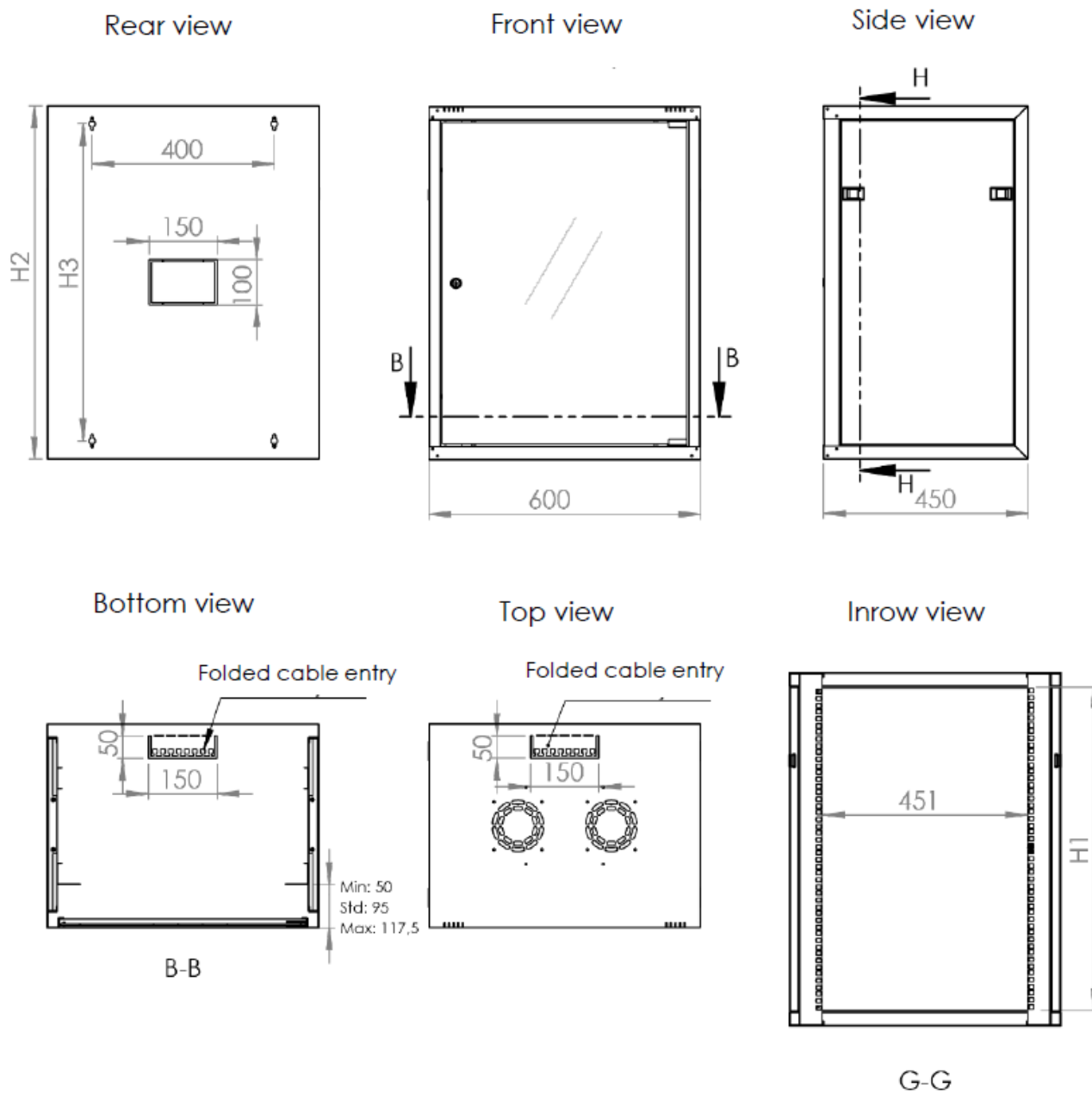

**Drawings for 600mm depth cabinets:**

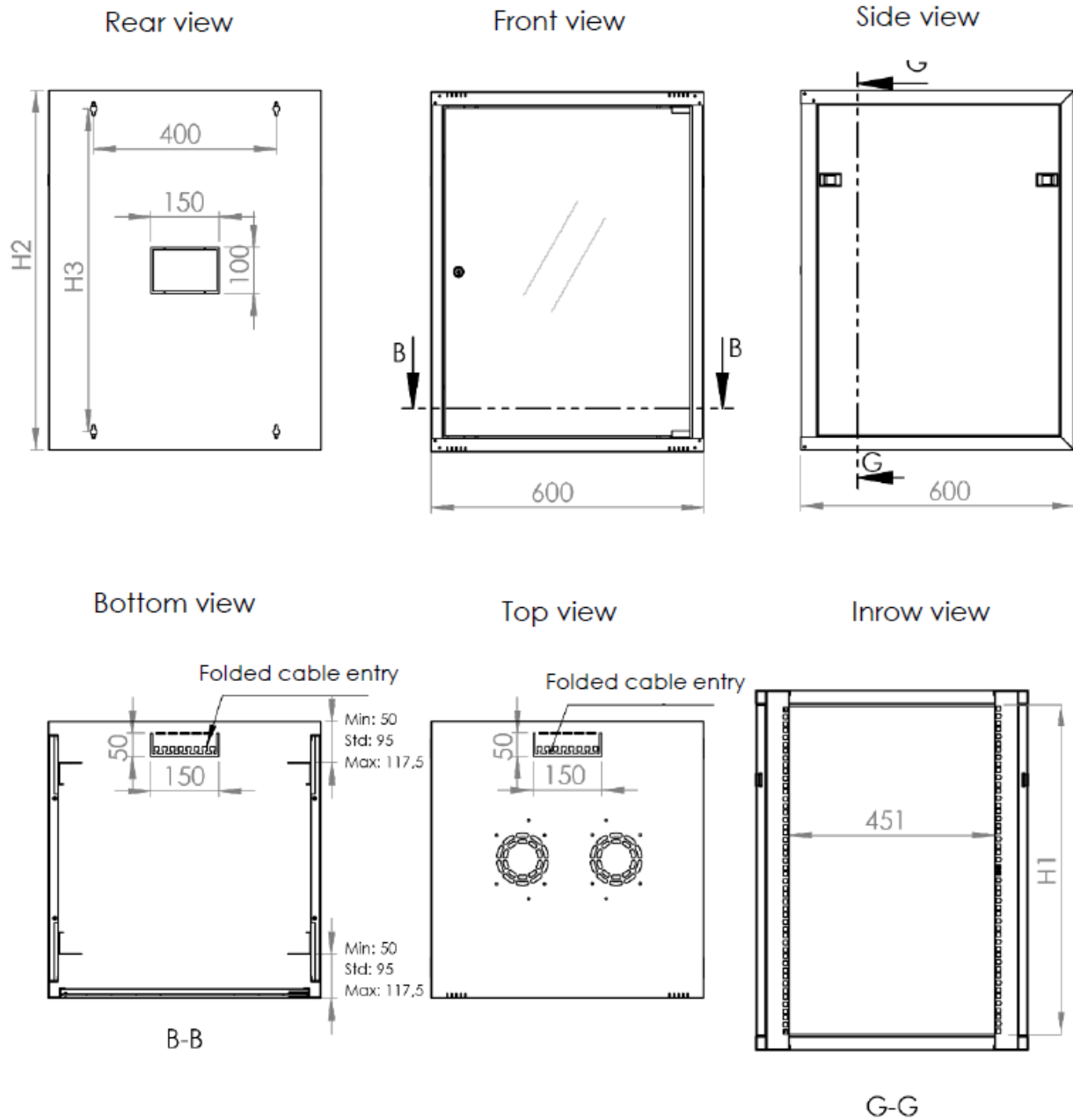

Part No.	Description	Width (W) mm	Depth (D) mm	H:1 Inner Height (mm)	H:2 Out Height (mm)	H:3 Wall Mounting Hole Distance
611fr6d07z-TW	Wall Net Cabinet 19" 7U W=600 mm	600	450/600	311	380	300
611fr6d09z-TW	Wall Net Cabinet 19" 9U W=600 mm	600	450/600	400	469	389
611fr6d12z-TW	Wall Net Cabinet 19" 12U W=600 mm	600	450/600	533	602	522
611fr6d16z-TW	Wall Net Cabinet 19" 16U W=600 mm	600	450/600	711	780	700

**Explode View:**

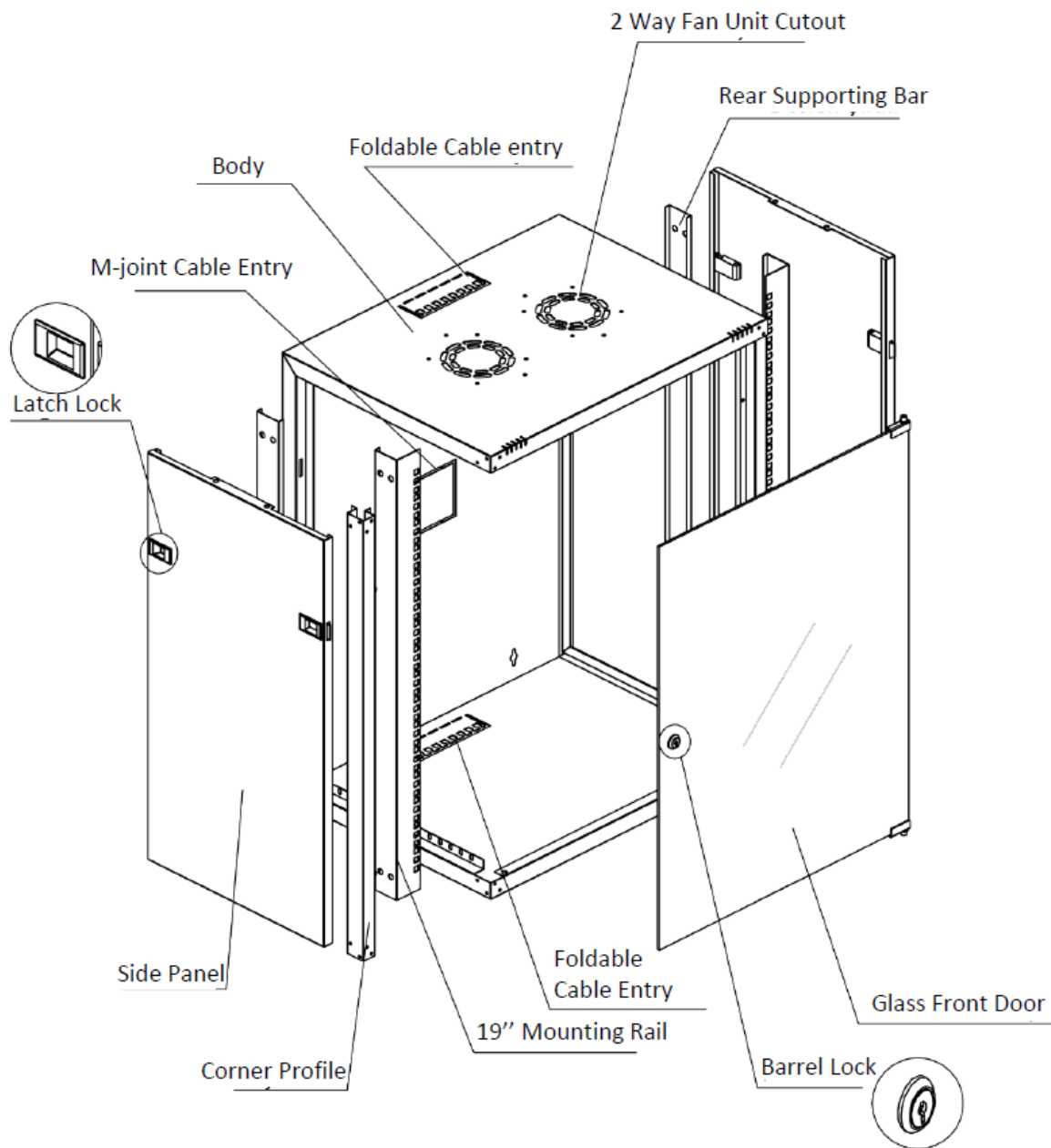

**Optional Doors:**

**FRONT DOOR OPTIONS**

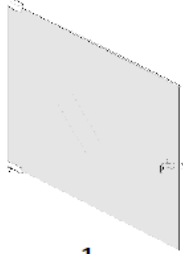

**1**  
Hinged Smoked  
Glass Front Door



**2**  
Hinged Metal  
Front Door

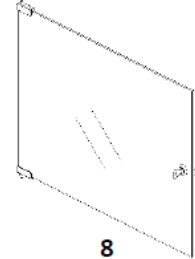

**8**  
Hinged Glass  
Front Door

**REAR DOOR OPTIONS**

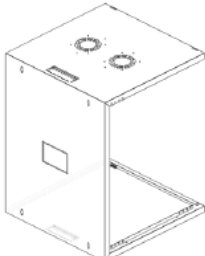

**1**  
Fixed Rear Body

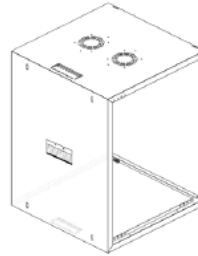

**2**  
Fixed Rear Body with Brush

**Ordering Information:**

Part No.	611fr6dyyz-TW
Description	WALL NET Cabinet W:600mm, removable side panels
f, front door	1 - Hinged Glass Opening Front Door Metal Side Frames; etc
r, rear door	1 - Fixed Rear Body; etc.
d, depth	4 – 450mm; 6 – 600mm
yy, height in Units (U)	07-7U;09-9U;12-12U; 16-16U
z, color/packing	2 - RAL 9005 Black color; 5 - RAL 7035 L.gray color

Premium-Line Systems GmbH, Rosenheimer Str.89, D-83064 Raubling, Germany

► TEL: + 49(0)8035 9836 0 ► Fax: + 49(0)8035 9836 22

Premium Line Systems GmbH reserves the right to change specifications without prior notice.