

**FEATURES:**

Category 6 U/UTP retail patch cord is using:

- RJ45 contacts 50µ inch gold plated
- Molded snag proof boot

Compliant with Cat.6 standards as:

- ANSI/TIA 568.2-D:2018
- ISO/IEC 11801-1 Class E:2017
- CENELEC EN 50173-1:2018
- CENELEC EN 50288-6-2:2013
- IEC 61935-2:2010 (Edition 3.0)
- IEC 61156-6:2012
- ETL Verified

Compliant with safety standards as:

- IEC 60332-1-2:2004
- RoHS compliant (EU Directive 2011/65/EC)



**CHARACTERISTICS:**

Conductor	Material / Size	Bare Copper / 24 AWG	
Insulation	Material	HDPE	
	Diameter	1.05 ± 0.06 mm	
Sheath	Material	PVC	LS0H
	Diameter	5.8 ± 0.2 mm	5.8 ± 0.2 mm
Operation Temperature		-20°C~+60°C	
Installation Temperature		0°C~+50°C	
Storage Temperature		-30°C~+60°C	

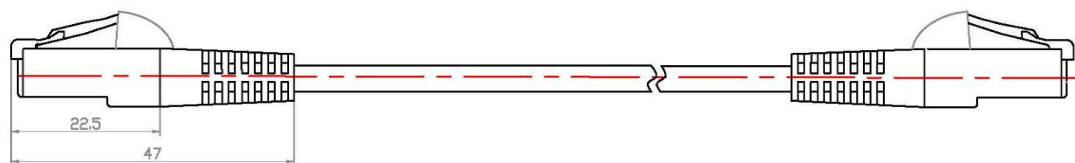

Premium Line Systems GmbH reserves the right to change specifications without prior notice.

**APPLICATION:**

- 1000BASE-TX Gigabit Ethernet
- 1000BASE-T Gigabit Ethernet
- 100BASE-TX Fast Ethernet
- 10BASE-T Ethernet
- Voice, Video and other applications

**ORDERING INFORMATION:**

Part No. 1861xyyyz  
 Description Cat. 6 U/UTP retail patch cord  
 x: sheath 1: PVC, 2: LSOH  
 yyy: length 005: 0.5m, 010: 1.0m, 020: 2.0m, 030: 3.0m, 050: 5.0m, 070: 7.0m, 100: 10.0m  
 z: color 0: orange, 1: white, 2: black, 3: red, 4: blue, 5: grey, 6: green, 8: yellow  
 Packing 1pc / PE bag

length	0.5m	1.0m	2.0m	3.0m	5.0m	7.0m	10.0m
quantity/carton	250pcs	200pcs	150pcs	120pcs	70pcs	60pcs	45pcs

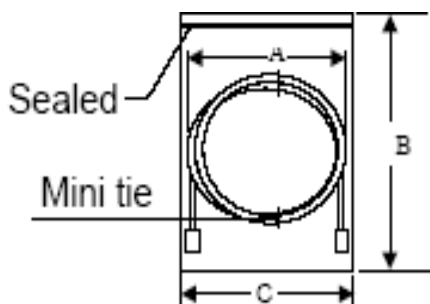

Packing	Length	$L \leq 3m$	$3m < L \leq 10m$	$10m < L$
	(A) mm	180+/-5	180+/-5	175~205
	Cable width			
	(BxC) mm	280x203	305x240	305x240
	PE bag size			
Carton size	42*42*25cm			

**Premium-Line Systems GmbH, Rosenheimer Str. 89, D-83064 Raubling, Germany**

**► TEL: + 49(0)8035 9836 0 ► Fax: + 49(0)8035 9836 22**

*Premium Line Systems GmbH reserves the right to change specifications without prior notice.*