

FEATURES:

Category 6A S/FTP SlimLine Patch Cord is using:

- RJ45 contacts 50µ inch gold plated
- Molded snag proof boot

Compliant with Cat.6A standards as:

- ANSI/TIA 568.2-D:2018
- ISO/IEC 11801-1 Class Ea:2017
- CENELEC EN 50173-1:2018
- CENELEC EN 50288-10-2:2015
- IEC 61935-2:2010 (Edition 3.0)
- IEC 61156-6:2012



Compliant with safety standards as:

- IEC 60332-1-2:2004
- RoHS compliant (EU Directive 2011/65/EC)

CHARACTERISTICS:

Conductor	Material / size	Bare Copper / 34 AWG	
Insulation	Material	PE	
	Diameter	0.55 ± 0.05 mm	
Inner-Shield	Aluminum-Mylar	an aluminum foil screen around each pair	
Braid	Material	Tinned Copper	
Sheath	Material	PVC	LSOH
	Diameter	4.0 ± 0.2 mm	4.0 ± 0.2 mm
Operation Temperature		-20°C~+60°C	
Installation Temperature		0°C~+50°C	
Storage Temperature		-30°C~+60°C	

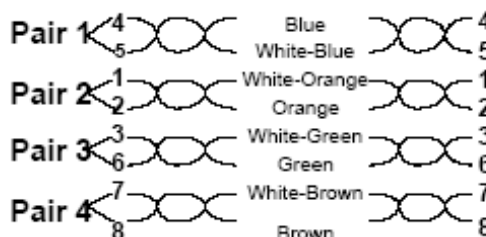
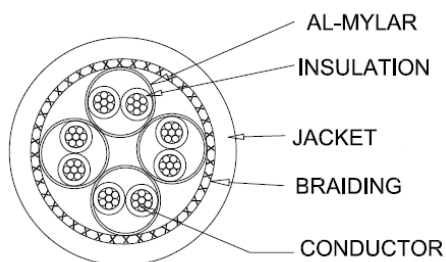

APPLICATION:

- 10G BASE-T Ethernet
- 1000BASE-TX Gigabit Ethernet
- 1000BASE-T Gigabit Ethernet
- 100BASE-TX Fast Ethernet
- 10BASE-T Ethernet
- Voice, Video and other applications

ORDERING INFORMATION:

Part No: 1820xyyyz
 Description Cat.6A S/FTP SlimLine patch cord
 x: sheath 1: PVC 2: LSOH
 yyy: Length 003: 0.3m, 005: 0.5m, 010: 1.0m, 020: 2.0m
 z: Color 1: white, 2: black, 3: red, 4: blue, 5: grey, 6: green, 8: yellow
 Packing 1pc / PE bag

length	0.3m	0.5m	1m	2m
quantity/carton	600pcs	500pcs	400pcs	300pcs

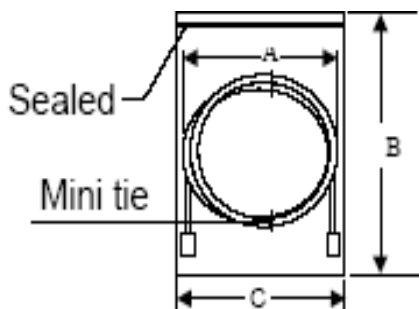

Packing	Length	L ≤ 2m
	(A) mm	180+/-5
	Cable width	
	(B×C) mm	280×203
	PE bag size	
Carton size	40*40*23cm	

Premium-Line Systems GmbH, Rosenheimer Str.89, D-83064 Raubling, Germany

► **TEL: + 49(0)8035 9836 0** ► **Fax: + 49(0)8035 9836 22**

Premium Line Systems GmbH reserves the right to change specifications without prior notice